

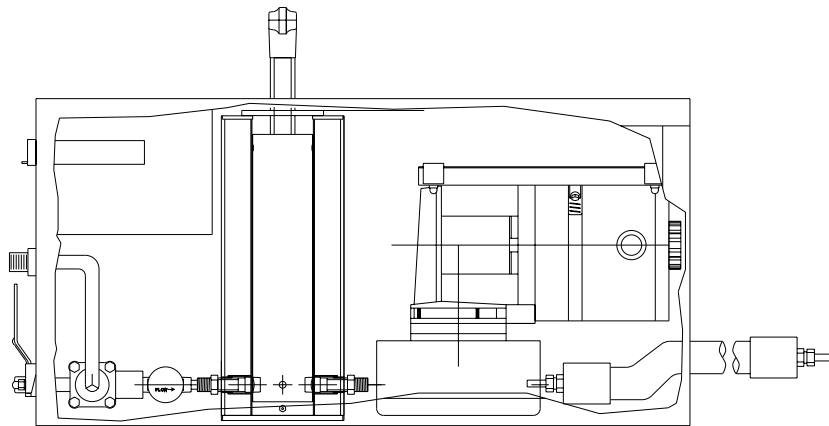

Emissions Sample Transport Systems
1091 Wheaton Ave. Troy, MI 48083
248-528-9640 fax 248-528-9643
www.atmoseal-eng.com

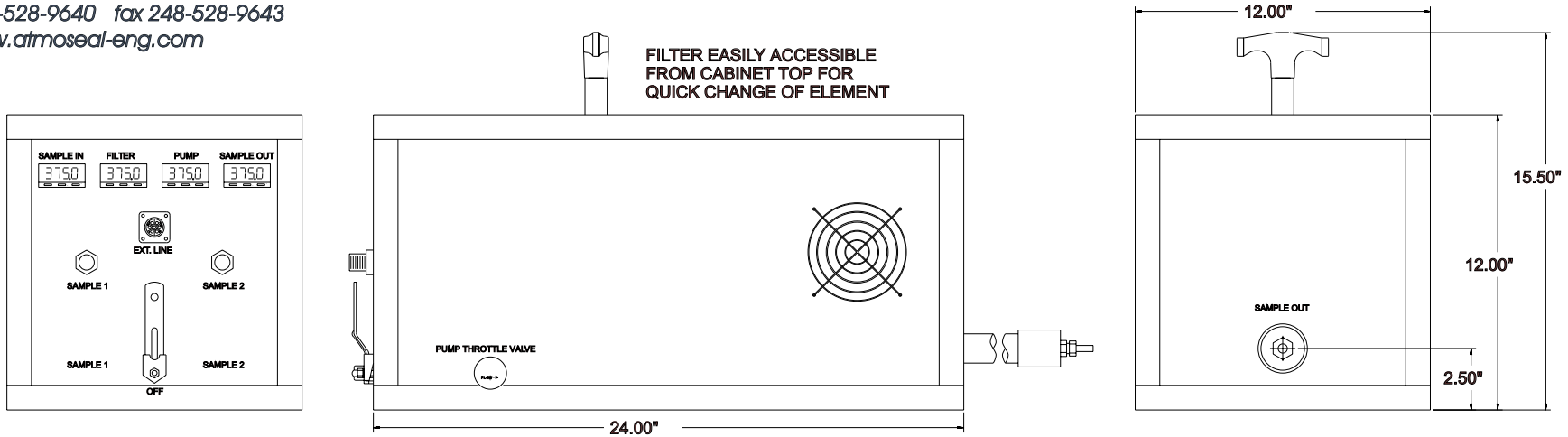

ENTIRE SAMPLE TRAIN IS HEAT TRACED

DHS-J11

Heated Sample Conditioning System

- User-Adjustable temperature up to 200 C
- Dual-Selectable Sample Inputs
- Entire sample system is Heat-Traced
- Quick Change filter element accessible from the cabinet top
- Uses standard 1 x 7 filter elements, filtration level selected by user
- All SS/Teflon wetted components in the sample stream
- Four individual control zones (two for heated lines, two for internal system) ensure a precise sample temperature.
- User adjustable flow from 0-12-LPM @ 150 C, 1-10- LPM @ 191 C
- Designed to interface with ASE Heated Emissions Sample Lines, Teflon, SS, Thin wall SS and Corrugated SS all are available